

# INCEPTOR® NANO<sup>V2</sup>

## Technical Specification

Product Code: OV5700CH5CD

Description: 5.5W LED Fixed Dimmable Downlight IP65 CW Chrome

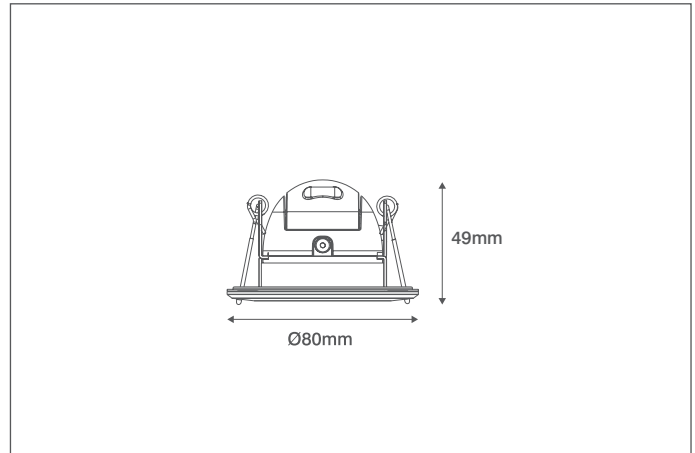

### General Information

Dimensions (mm)	80 (Dia.) x 49 (D)
Materials	Bezel: Aluminium (Plated or Powdercoated) Rear Frame: Steel Rear Housing: ABS Lens: Polycarbonate
Finish	Polished Chrome
Product Weight (Kg)	0.24
Cutout Diameter (mm)	60
Recess Depth (mm)	45
Ingress Protection	IP65
Airflow (BS 5250)	0.05m <sup>3</sup> /h m <sup>2</sup> at a pressure difference of 2 Pa
Warranty (Years)	5

### Supply & Power Information

Input Voltage & Frequency (V~ / Hz)	200-240 50/60
Safety Class	II
Circuit Wattage (W)	5.5
Input Current (mA)	27-35
Inrush Current/Time	2.03A (700ms)
Power Factor	0.8
Operating Temperature (°C)	-20 to +40
Critical Temperature (°C)	+80
Driver Information	Integrated Within Flow™ Connector
Prewired Flow™ Connector	Yes (3 Pole CT105-F Push-in Terminals)

### Luminaire Output

Colour Temperature (K)	4000
Colour Render Index (CRI)	>80
Typical Luminous Flux (lm)	565
Efficacy (lm/W)	103
Beam Angle (°)	60
LED Lifetime (L70) (Hours)	35,000

### Dimming Information

Dimmable	Yes
----------	-----

### Compatible Accessories

OVISC1020 - Insulation Support Bracket  
OVSP4120CH - 130mm Diameter Converter Plate - Chrome  
OVEMCG2305M3 - 3 Hour Universal Emergency Pack with prewired Flow™ Connectors

### Additional Approvals

Fire Rating	30 Minutes: 'I' Joists, Metal Web and Solid Timber Joists 60 Minutes: 'I' Joists, Metal Web and Solid Timber Joists 90 Minutes: Solid Timber Joists
Acoustic Rating	0dB (zero impact on sound insulation)
Air Flow	BS 5250: 2011 compliant

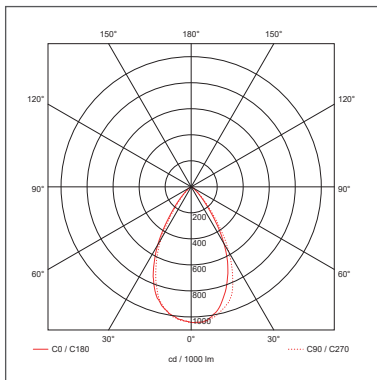

OVIA Limited, Scolmore House, Mariner, Lichfield Road Industrial Estate,  
Tamworth, Staffordshire, B79 7UL United Kingdom

T: +44 (0)1827 300640

E: sales@oviaUK.com | W: oviaUK.com